

Technical data sheet

Product features



Pizza oven 1 chamber 9x d=33 cm

Model	SAP Code	00007281
--------------	-----------------	----------



- Pizza capacity [cm]: 9x 33 cm
- Stoneplates: Bottom and top
- Material: Stainless steel
- Control type: Mechanical
- Steam protection: Yes
- Independent heating zones: Separate control for each chamber, separate control for the upper and lower heating element
- Type of construction: single storey
- Chimney for moisture extraction: Yes
- Adjustable chimney: Yes
- Interior lighting: Yes

SAP Code	00007281	Minimum device temperature [°C]	50
Net Width [mm]	1305	Maximum device temperature [°C]	450
Net Depth [mm]	1185	Width of internal part [mm]	1050
Net Height [mm]	412	Depth of internal part [mm]	1050
Net Weight [kg]	148.00	Height of internal part [mm]	150
Power electric [kW]	12.000	Pizza capacity [cm]	9x 33 cm
Loading	400 V / 3N - 50 Hz		

Technical data sheet

Technical drawing



Pizza oven 1 chamber 9x d=33 cm

Model

SAP Code

00007281

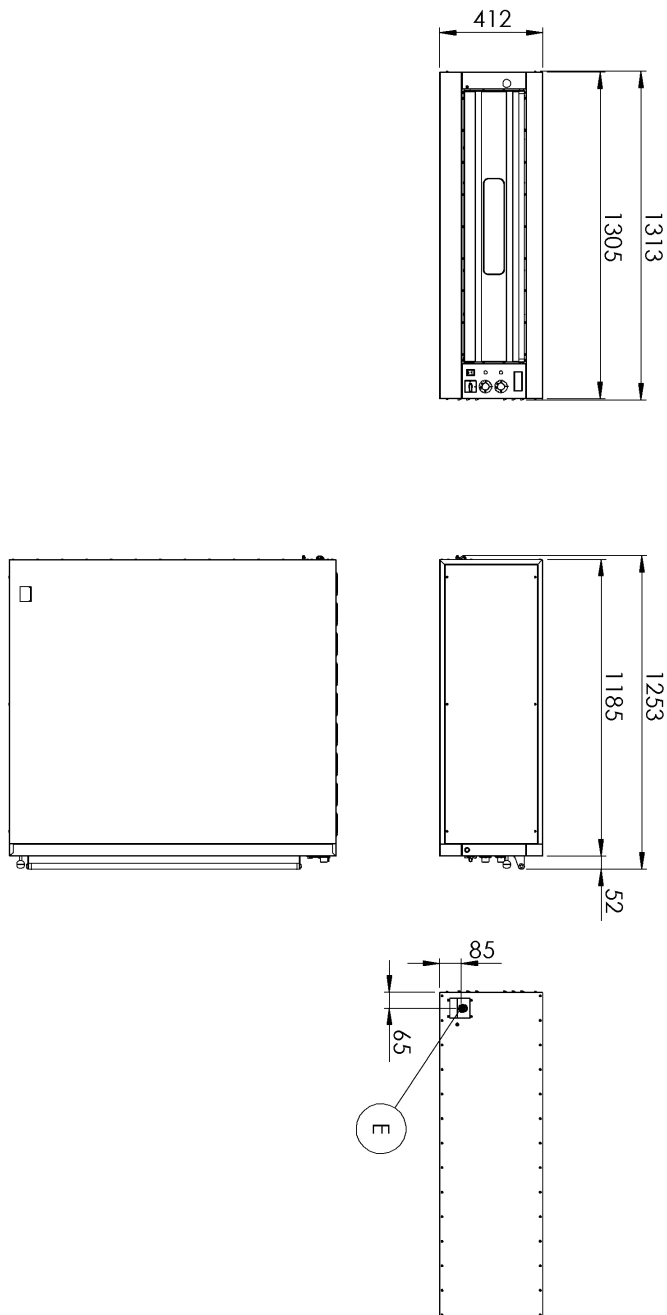

Technical data sheet

Product benefits



Pizza oven 1 chamber 9x d=33 cm

Model

SAP Code

00007281

1

Stainless steel outer shell construction

easy cleaning, high hygienic standard, long service life

- cost savings on the purchase of a new machine, time savings on cleaning and cleaning comfort

2

Chamber heating in the temperature range of 50 to 450°C

the temperature range enables the preparation of various types of dough and meat; can also be used for baking

- we have a crispy pizza in a short time - I can make a pizza according to the dough, the customer does not wait long and the operator serves multiple customers - multiple turns in one oven

3

Fireclay plate 14mm placed below with heaters under the plate

proper accumulation and uniformity of heat distribution

- no scorching and the pizza is evenly cooked and does not burn, no temperature fluctuation, no need for the cook to check and adjust the baking, lower demands on the knowledge and skills of the pizza maker

4

Glass set in the door

checking the product during heat treatment without having to open the door

- I don't lose temperature when baking by unnecessarily opening the door without glass, saving energy

5

2x thermostat, separate control of upper and lower heaters

more precise regulation of heat in the chamber, according to the type of dough or food

- better final quality of the product; no burning, variability - suitable for different treatments, better comfort for the experienced cook, suitable for professionals

6

Digital chamber thermometer

better visibility than analog
accurate data

- easier operation

Technical data sheet

Technical parameters



Pizza oven 1 chamber 9x d=33 cm

Model

SAP Code

00007281

1. SAP Code:

00007281

2. Net Width [mm]:

1305

3. Net Depth [mm]:

1185

4. Net Height [mm]:

412

5. Net Weight [kg]:

148.00

6. Gross Width [mm]:

1285

7. Gross depth [mm]:

1405

8. Gross Height [mm]:

512

9. Gross Weight [kg]:

150.00

10. Exterior color of the device:

Stainless steel

11. Material:

Stainless steel

12. Device type:

Electric unit

13. Power electric [kW]:

12.000

14. Loading:

400 V / 3N - 50 Hz

15. Control type:

Mechanical

16. Width of internal part [mm]:

1050

17. Depth of internal part [mm]:

1050

18. Height of internal part [mm]:

150

19. Minimum device temperature [°C]:

50

20. Maximum device temperature [°C]:

450

21. Stacking availability:

Yes

22. Pizza capacity [cm]:

9x 33 cm

23. Thermometer:

Analog

24. Indicators:

running and heating the oven

25. Number of internal parts:

9

26. On/Off button:

Yes

27. Steam protection:

Yes

28. Protection of controls:

IPX4

Technical data sheet

Technical parameters



Pizza oven 1 chamber 9x d=33 cm

Model

SAP Code

00007281

29. Stoneplates:

Bottom and top

30. Independent heating zones:

Separate control for each chamber, separate control for the upper and lower heating element

31. Type of construction:

single storey

32. Interior lighting:

Yes

33. Safety element:

thermostat

34. Number of cavities:

1

35. Chimney for moisture extraction:

Yes

36. Adjustable chimney:

Yes